

State of Hawaii  
DEPARTMENT OF LAND AND NATURAL RESOURCES  
Division of Aquatic Resources  
Honolulu, Hawaii 96813

July 13, 2012

Board of Land  
and Natural Resources  
Honolulu, Hawaii

REQUEST FOR APPROVAL TO AUTHORIZE THE DEPARTMENT OF LAND AND  
NATURAL RESOURCES CHAIRPERSON TO ENTER INTO A FEDERALLY FUNDED  
CONTRACT (\$387,000) BETWEEN DLNR AND PIONEER MACHINERY, INC. FOR THE  
CASTING/MANUFACTURING AND DELIVERY OF ARTIFICIAL REEF HABITATS

Submitted for your consideration and approval is a request to enter into a Contract with Pioneer Machinery, Inc. for an initial twelve (12) month period with three (3) options to extend for additional twelve (12) month periods. The federally funded Contract uses funds from a U.S. Fish and Wildlife Service Sport Fish Restoration grant awarded to the Department's Division of Aquatic Resources. No State funds are being used. Pioneer Machinery was the lowest and responsible bidder at \$387,000.00, reference IFB DAR-2012-002, Pursuant to HRS 103D 302, which closed on May 31, 2012.

This project consists of the construction and delivery of the artificial reef habitats to Pier 60 located at Sand Island, Oahu, or another pier as designated by the State. The concrete for this project is donated excess concrete from Ameron HC & D. Each habitat weighs about 2,500 pounds, or if deep-water prototype is designated, will weigh about 4,000 pounds each. The annual quantity is estimated at 1,800 habitats.

Attached is the copy of the Governor's approval for the expenditure of the federal funds.

RECOMMENDATION:

"That the Board authorize the Chairperson to enter into a contract with Pioneer Machinery, Inc., subject to all necessary approvals."

Respectfully submitted,

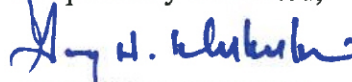

GUY KAULUKUKUI  
Acting Administrator

APPROVED FOR SUBMITTAL:



WILLIAM J. AILA, JR.  
Chairperson

Attachment

ITEM F-1



# Solicitation Number: IFB DAR-2012-002

ID: 987

Posted by: Ray Uchimura

Department: Department of Land and Natural Resources

County/Island(s): Statewide

Category (Select One): Goods & Services

Publication Date: 05/11/2012

Due Date: 05/31/2012 - 15:00PM HST

Solicitation Number: IFB DAR-2012-002

Description: Casting/Manufacturing and Delivery of Artificial Coral Reef habitats to Pier 60, Sand Island Road, Honolulu, HI. See attached for Scope of Work and Specifications of the habitats.

Contact Name: Paul Murakawa

Phone Number: 808-253-9826

E-mail Address: Paul.Y.Murakawa@hawaii.gov

Comments: Bid forms are attached for submission.

IFB/RFP/RFI, Professional Svcs., etc. documents: ifb-dar-2012-002.pdf

## Pre-Bid / Pre-Proposal / Orientation Conference

Conference Scheduled:

Date/Time:

Address:

City:

Zip Code:

Additional Info:

## Addenda

Amended:

Date Last Amended:

Submission Date: 05/11/2012 - 09:11AM

Last Modified: 05/11/2012 - 09:11AM

<b>Island</b>	<b>Category</b>	<b>Description</b>	<b>Publication Date</b>	<b>Due Date</b>	<b>Info</b>
Kauai	Construction	IFB 12-0470, Renovate Classroom to Science Lab Bldg. 4458, Kauai CC	05/09/2012	06/06/2012	More Info
Oahu	Construction	IFB 12-0520, Bilger Hall / Bilger Addition, Replace Fire Alarm System, University of Hawaii at Manoa	05/09/2012	06/21/2012	More Info

Showing 1 to 10 of 183 entries

216

**CASTING/MANUFACTURING AND DELIVERING OF ARTIFICIAL REEF HABITATS**  
**IFB DAR-2012-002**

William J. Aila, Jr.  
Procurement Officer  
State of Hawaii  
Honolulu, Hawaii 96813

Dear Mr. Aila:

The undersigned Bidder has carefully read and understands the terms and conditions specified in the Specifications and Special Provisions attached and included by reference, the AG General Conditions, Form AG-008, as revised; and hereby submits the following bid to perform the work specified.

The Bidder acknowledges and agrees that by submitting this bid, Bidder is, 1) not in violation of Chapter 84, Hawaii Revised Statutes, concerning prohibited State contracts, and 2) certifying that the price(s) submitted was (were) independently arrived at without collusion.

Bidder is:

Sole Proprietor     Partnership     \*Corporation     Joint Venture  
 Other \_\_\_\_\_

\*State of incorporation: Hawaii

Hawaii General Excise Tax License I.D. No. W 20353676-01

Payment address

(other than street address below):

P.O. Box 22265

City, State, Zip Code:

Honolulu, Hawaii 96823-2265

Business address (street address):

3476 Ala Hinalo Street

City, State, Zip Code:

Honolulu, Hawaii 96818

Respectfully submitted:

(x)

Rodney T. Yee

Authorized (Original) Signature

Rodney T. Yee, President  
Name and Title (Please Type or Print)

\*\* Pioneer Machinery, Inc.  
Exact Legal Name of Company (Offeror)

Date:

5-31-12

(808) 371-4892

Telephone No.:

(808) 833-5614

Fax No.:

allstaryee@gmail.com  
E-mail Address:

\*\*If Bidder is a "dba" or a "division" of a corporation, furnish the exact legal name of the corporation under which the awarded contract will be executed (Corporate Resolution Required)

**BID FORM-1**

**IFB DAR-2012-002**

The following bid is hereby submitted to furnish and deliver Artificial Reef Habitats, hereafter habitats, as specified, for the Department of Land and Natural Resources, Division of Aquatics Resources, the State.

<u>Description</u>	<u>Estimated Annual Quantity (average)</u>	<u>Unit Bid Price</u>	<u>Estimated Total Annual Bid Price (average)</u>
Artificial Reef Habitats	1800 Habitats	\$ <u>215.00</u> each Habitat	\$ <u>387,000.00</u>

**Note:** Estimated annual quantity average is based on approximately 1200-1800 habitats. This is a result of approximately 400-600 habitats ordered every fourth month of the calendar year.

**Bidder shall provide the following information:**

Location of Facility: 50 P. Sand Island Road  
2 Pier 60  
Telephone Number: (808) 371-4892  
Fax Number: (808) 833-5614  
Contact Person: Rodney T. Yee  
E-mail Address: allstar yee@gmail.com

ATTACHMENT A

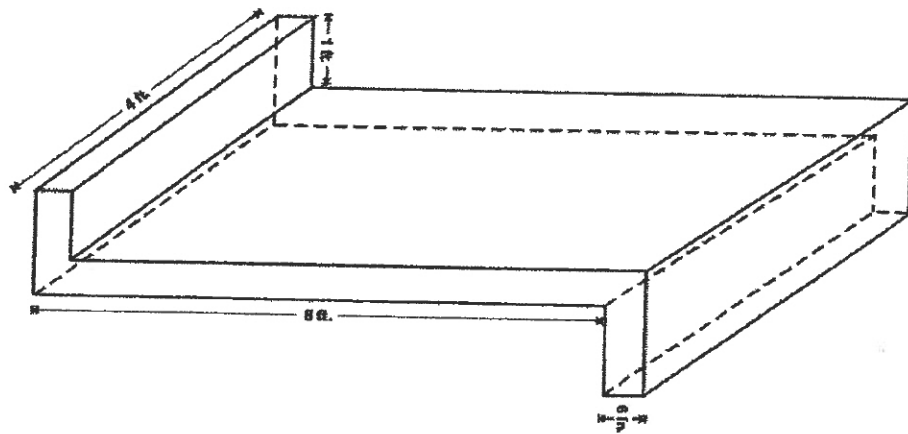

ATTACHMENT A

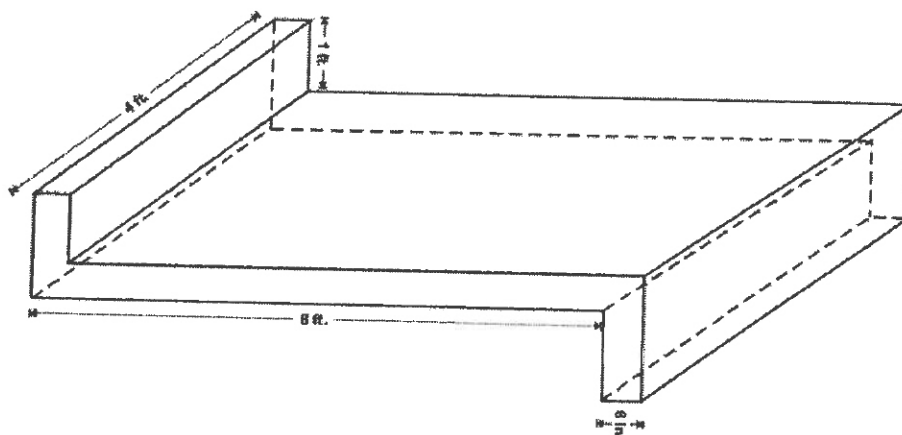

SPECIFICATIONS

NOT TO SCALE

IFB DAR-2012-002

12:0320534

NEEL ABERCROMBIE  
GOVERNOR OF HAWAII



WILLIAM J. AILA, JR.  
CHAIRPERSON  
BOARD OF LAND AND NATURAL RESOURCES  
COMMISSION ON WATER RESOURCE MANAGEMENT

GUY H. KAULUKUKUI  
FIRST DEPUTY

WILLIAM M. TAM  
DEPUTY DIRECTOR - WATER

4273

AQUATIC RESOURCES  
BOATING AND OCEAN RECREATION  
BUREAU OF CONVEYANCES  
COMMISSION ON WATER RESOURCE MANAGEMENT  
CONSERVATION AND COASTAL LANDS  
CONSERVATION AND RESOURCES ENFORCEMENT  
ENGINEERING  
FORESTRY AND WILDLIFE  
HISTORIC PRESERVATION  
KAHOOLAWE ISLAND RESERVE COMMISSION  
LAND  
STATE PARKS



STATE OF HAWAII  
DEPARTMENT OF LAND AND NATURAL RESOURCES

POST OFFICE BOX 621  
HONOLULU, HAWAII 96809

February 24, 2012



*Bdf: 1394*  
*S: 03/08/12*



TO: The Honorable Neil Abercrombie  
Governor, State of Hawaii

THROUGH: Honorable Kalbert K. Young, Director  
Department of Budget and Finance

FROM: William J. Aila, Jr., Chairperson *William J. Aila, Jr.*  
Board of Land and Natural Resources *WJA*

SUBJECT: Request for Approval to Expend Federal funds to 1) Contract Manufacture of Fish Shelters and 2) Contract Tug and Barges Services, for the State's Artificial Reef Project

Submitted herewith for your approval is a request to expend federal funds and hire contractors to build the fish shelters and to deliver them to the State's artificial reefs. Procurement of the contractors will be via the Competitive Sealed Bids (IFB) process pursuant to HRS 103D-302, HAR Chapter 3-122, Subchapter 5.

One IFB will be for the manufacturing of approximately 1500 fish shelters per year. The fish shelters are four feet (4') wide by eight feet (8') long and five inches (5") thick and weigh approximately 2500 pounds each. Each fish shelter will be reinforced with 90 linear feet of rebar. Estimated cost per fish shelter is approximately \$200; total estimated cost of \$300,000. The fish shelters are made from surplus concrete donated by the local concrete company. This donation is used as State matching funds to receive the federal funds. For each fish shelter that is purchased, the State gets a donation from Ameron Hawaii of \$93.75 (per module, .75 cu yd of concrete) for which the Division of Aquatic Resources (DAR) can get \$281.25 in federal funds. Because the concrete is free of charge, the artificial reef project uses only the federal funds in cash expenditure.

The second IFB will be for annual tug and barge for delivery to and deployment of the fish shelters at the selected site. The fish shelters will be loaded onto a barge and then towed by tug to one of the State's artificial reef locations. Prior to the deployment, DAR staff will conduct assessments of the deployment area to make sure it is devoid of sensitive and protected marine



Honorable Neil Abercrombie

February 24, 2012

Page 2

life. Buoys will be used to frame the target deployment area so that the fish shelters do not land outside of the deployment area. The estimated cost for the tug and a barge service is \$125,000 per year.

If you have any questions or need further information regarding this request, please contact Francis Oishi, Division of Aquatic Resources Program Manager, at 587-0094.

RECOMMEND:

APPROVAL                       DISAPPROVAL

  
\_\_\_\_\_  
KALBERT K. YOUNG  
Director of Finance

March 20, 2012  
DATE

APPROVED                       DISAPPROVED

  
\_\_\_\_\_  
NEIL ABERCROMBIE  
Governor, State of Hawaii

3-21-12  
DATE